

UR-W216/08

UNION RAIL WA WELDED BASE FIXING



Ph: 1800 099 788 | info@unionrail.com.au | www.unionrail.com.au

The Union Rail WA UR-W216/08 adjustable crane rail clip is designed to fix heavy rails in the most arduous applications.

It can withstand a horizontal force from the rail of 165kN

Its low profile allows it to be used with cranes that are fitted with guide rollers.

DIMENSIONS (mm):

REF NO.	A	B (FULL NUT)	C	WEIGHT kg
UR-W216-08-40	40	47	28	1.31
UR-W216-08-44	44	47	28	1.35

SPECIFICATIONS:

Max Side Load using Grade 8.8 Bolt: 135kN

Horizontal Rail Adjustment: 8 mm

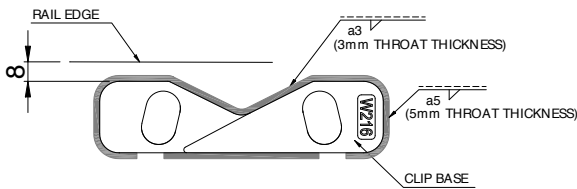

Weld along back and sides of clip base with a 5mm throat thickness fillet weld. Weld in 'V' with a 4mm throat thickness fillet weld. Use low hydrogen electrodes.

TIGHTENING TORQUE:

Grade 8.8 bolt 130Nm

RAIL WITH PAD

RAIL WITHOUT PAD

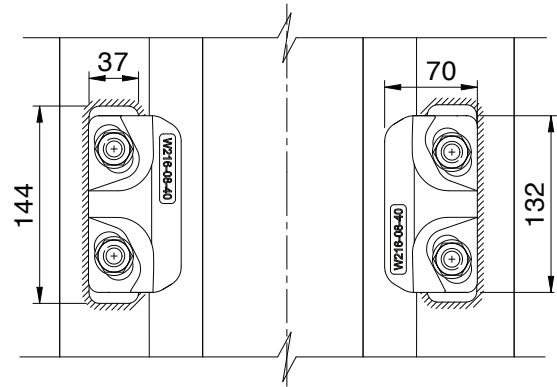
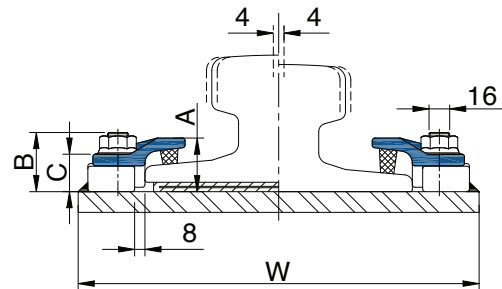

Minimum assembly width (W)=Rail Width(F)+100mm

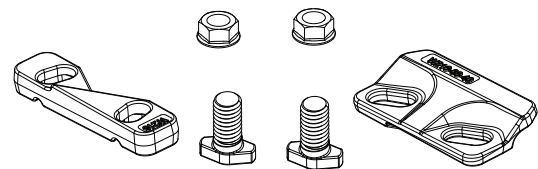

UR-W216/08

	F mm	T mm	H mm	RAIL WITH PAD	RAIL WITHOUT PAD
A 75	200	75	85	UR-W216-08-40	UR-W216-08-40
A 100	200	100	95	UR-W216-08-40	UR-W216-08-40
A 120	220	120	105	UR-W216-08-40	UR-W216-08-40
QU 80	130	80	130	UR-W216-08-40	UR-W216-08-40
QU 100	150	100	150	UR-W216-08-40	UR-W216-08-40
QU 120	170	120	170	UR-W216-08-40	UR-W216-08-40
CR 73	140	100	135	UR-W216-08-40	UR-W216-08-40
CR 100	155	120	150	UR-W216-08-40	UR-W216-08-40

This clip can be used for a wider selection of rails than illustrated. Please contact URWA for the full range of possible rails. URWA may change or improve their products and also alter specifications without notice.