

# UR-W16/115

## UNION RAIL WA WELDED BASE FIXING



Ph: 1800 099 788 | info@unionrail.com.au | www.unionrail.com.au

The Union Rail WA UR-W16/115 adjustable crane rail clip is designed to fix heavy rails, on narrow steel plate, in the most arduous applications. It can withstand a horizontal force from the rail of 125kN.

It's low profile allows it to be used with cranes that are fitted with guide rollers.

### Dimensions (mm):

REF NO.	A	B	C	WEIGHT
UR-W16-115-30	30	47	29	0.85 kg
UR-W16-115-38	38	47	29	0.92 kg
UR-W16-115-45	45	47	29	0.98 kg

### SPECIFICATIONS:

Max side load : 125kN  
Horizontal rail adjustment : 15mm

UR-W16/115

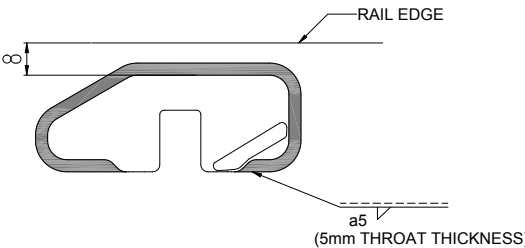

Weld all around the clip base with a 5mm throat thickness fillet weld using low hydrogen electrodes.

TIGHTENING TORQUE 220Nm  
Please contact URWA for rail without pad and full installation instructions.

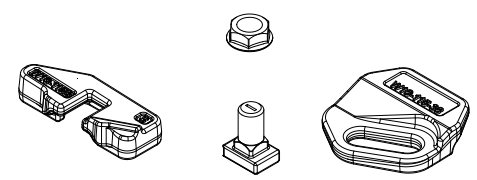

RAIL WITH PAD

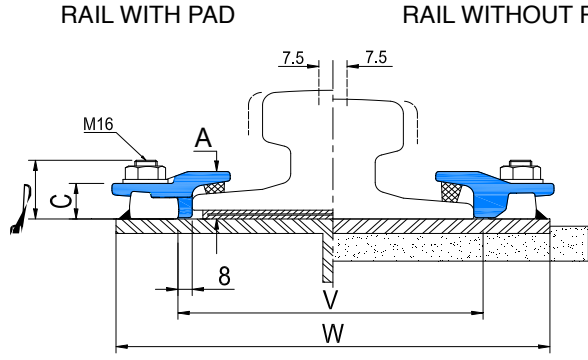

RAIL WITHOUT PAD

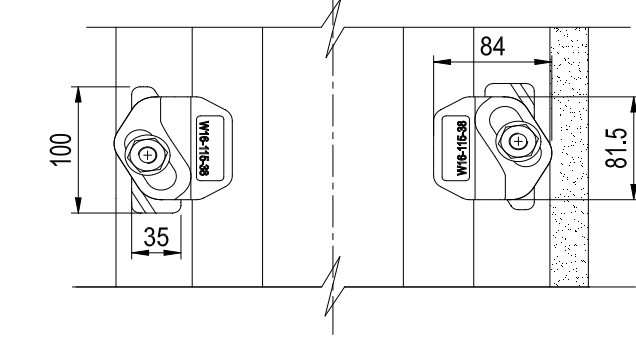

Minimum assembly width  $W = \text{Rail Width (F)} + 100\text{mm}$

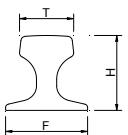
	F	T	H	RAIL WITH PAD	RAIL WITHOUT PAD
	mm	mm	mm		
A45	125	45	55	W16-115-38	W16-115-30
A55	150	55	65	W16-115-38	W16-115-30
A65	175	65	75	W16-115-38	W16-115-30
A75	200	75	85	W16-115-38	W16-115-30
A 100	200	100	95	W16-115-38	W16-115-30
MRS87A	152	102	152	W16-115-45	W16-115-38
A 120	220	120	105	W16-115-38	W16-115-30
QU 70	120	70	120	W16-115-38	W16-115-30
QU 80	130	80	130	W16-115-38	W16-115-30
UIC54	140	70	159	W16-115-38	W16-115-30
ASCE80	127	64	127	W16-115-38	W16-115-30

This clip can be used for a wider selection of rails than illustrated. Please contact URWA for the full range of possible rails. URWA may change or improve their products and also alter specifications without notice.